



# Product Data Sheet

## CCT 1000-TL D (+55°C)

### Relevant Test Standards:

#### Cyclic Corrosion Tests:

- DIN EN ISO 11997-1:2006 Cycle B (previously VDA 621-415)
- VW PV 1210 (climate module required)

#### Water Condensation Tests:

- DIN EN ISO 6270-2:2005
- BS 3900 F2
- BS 3900 F15
- ASTM D2247



#### Salt Spray Tests:

- DIN EN ISO 9227
- DIN 50942, DIN 53167
- ASTM B 117-73, ASTM B 287-74
- ASTM B 368-68
- ISO 7253 ISO 3678
- BS 1224, BS 2011, BS3900 F4
- BS 3900 F12
- BS 5466 Part I, BS 5466 Parts 2 + 3
- NFX 41002,
- AS 21331 Section 3.1
- SIS 1841190
- JIS Z 2371
- IEC 60028-2-11 KA

### Legend

CH – Constant Humidity

AT – Alternating Temperature

AHT- Alternating Humidity and Temperature

AIR – Forced air circulation

AWRF – Automatic water refill

### Order Information

Basic model: CCT 1000-TL D

Article numbers:

- V.735.065.650

### Sales & Support:

+49 5205 87963 0

Monday to Friday

8:00 am – 17:00 pm

VLM GmbH

Heideblümchenweg 50

33689 Bielefeld

[info@vlm-labtec.com](mailto:info@vlm-labtec.com)

[www.vlm-labtec.com](http://www.vlm-labtec.com)

Specification subject to changes

Pictures might differ from original



### Product Description

Compact top loading corrosion test chest developed for conducting automated cyclic corrosion tests pursuant to the most common corporate (automotive) and international corrosion standards such as:

- DIN EN ISO 11997-1:2006 Cycle B (previously VDA 621-415)
- VW PV 1210 (external climate module required)

This cabinet can also conduct standard corrosion tests:

- DIN EN ISO 6270-2:2005 (CH, AT, AHT)
- ASTM D2247
- ISO 9227
- IEC 60028-2-11 KA

### Customer Benefits

- Operating temperature from ambient up to +55 °C
- Time and energy savings over the operational lifetime - the bottom of the test chamber is made of steel which allows fast and uniform heat transfer making this test chamber perfectly suitable for accelerated corrosion tests
- The steel bottom of the test chamber makes the test chamber more robust and less susceptible for damages compared to the competitive products made of glass reinforced plastic
- Lower total cost of ownership compared to the competitive products where the test chamber is completely made of glass reinforced plastic (shorter test periods, better energy efficiency, easier for service and maintenance, longer life cycle, more resistive to mechanical damages)
- User friendly, intuitive and versatile controller (Jumo Dicon touch) with touch screen, data logging, Ethernet interface and password protection - most common corrosion tests are already preconfigured



# Product Data Sheet

## CCT 1000-TL D (+55°C)

### Relevant Test Standards:

#### Cyclic Climate Tests:

- DIN EN ISO 11997-1:2006 Cycle B (previously VDA 621-415)
- VW PV 1210 (climate module required)

#### Water condensation tests:

- DIN EN ISO 6270-2:2005
- BS 3900 F2
- BS 3900 F15
- ASTM D2247



#### Salt Spray Test:

- DIN EN ISO 9227
- DIN 50942, DIN 53167
- ASTM B 117-73, ASTM B 287-74
- ASTM B 368-68
- ISO 7253 ISO 3678
- BS 1224, BS 2011, BS3900 F4
- BS 3900 F12
- BS 5466 Part I, BS 5466 Parts 2 + 3
- NFX 41002,
- AS 21331 Section 3.1
- SIS 1841190
- JIS Z 2371
- IEC 60028-2-11 KA



Figure 1 Jumo Dicon touch controller

### The following accessories are included:

- 6 rods for supporting test specimen
- 2 m exhaust hose Ø 75 mm
- 2 m drain water hose Ø 32 mm
- 1 female connector for compressed air hose (size no. 5)



### Technical Specifications

Capacity	ca. 1000 L
Inner test chamber dimensions W/D/H1/H2	ca. 1425 x 800 x 690 / 1005 mm
Outer dimensions of the casing (overall) W/D/H	ca. 1895 x 890 x 1265 mm
Required power supply	230V, 50/60Hz, 2500W
Materials used	The walls of the chamber are made of Polypropylene while the bottom is made of stainless steel and coated with ECTFE. The walls have milled openings for supporting rods
Heating	Flat Micanite heaters under the bottom of the chamber for fast and uniform heat transfer
Sensors	- 1x corrosion resistant and highly sensitive temperature sensor
Temperature stability	±0,5°C
Aeration (type AIR)	timer controlled built-in fan (capacity ca. 16 m <sup>3</sup> /h)
Controller	Jumo Dicon touch programmable controller
Weight	250 kg
Communication	Ethernet interface

### Other specification

Purity demi water / fitting	< 5 µS/cm / ¼" outer diameter
Tap water (connection type)	Always via Ion-exchanging cartridge (¾" outer diameter)
Compressed Air	6-8 bar (connection nipple size 5)
Waste water, drain	Pipe fittings (spiral hose 32mm)
Air exhaust pipe outer diameter	Pipe fitting (75 mm external diameter)
Number of supporting rods / max load	6 stainless steel rods coated with plastic / 30 kg each

### Process Control

- User friendly, programmable Jumo Dicon touch controller with touch screen, data logging, Ethernet interface
- Restricted access for operators to three different operating levels
- Memory storage with the capacity to hold up to 50 test programs, most common corrosion tests are already preconfigured in the factory
- The controller steers the external climate module for the tests that require air conditioning (typically PV 1210)
- Full overview of all digital and analog inputs / outputs

### Operating System Water Condensation (CH) according to ISO 6270-2

- Flat heaters under the bottom of the chamber for uniform and rapid heating of the water in the trough
- Temperature stability inside the chamber ±0,5°C
- Automatic refilling of the test chamber (AWRF) for maintaining the constant water level in the trough
- Parameters for standard water condensation tests are already preconfigured

### Operating System Aeration

- Aeration with environmental air drying
- Adjustable air distribution system inside the test chamber for uniform drying of the test specimens
- Fan with controllable rotation speed
- **Option:** Air conditioning module for providing standard climate acc. to DIN 50014 (ISO 554): 23°C ±2°C and 50% ±5% RH



# Product Data Sheet

## CCT 1000-TL D (+55°C)

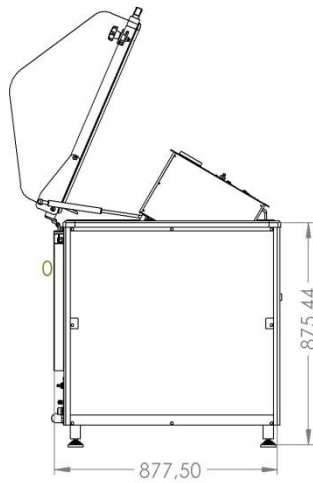

### Operating System Salt Spray (according to ISO 9227)

- Electronically controlled diaphragm pump for accurate flow control of test solution
- Adjustable high performance acrylic spray nozzle for optimal generation and distribution of the salt fog
- Transparent humidifier made of heat resistant Borosilicate glass with a replaceable PE air filter
- Safety air pressure valve on the humidifier
- Over temperature protection of the humidifier
- Air purge function for rapid evacuation of the salt fog out of the chamber
- **Accessories:** 210 L PE storage reservoir for test solution (level indicator optional)
- **Option:** Nozzle for washing the test chamber after the salt spray test is finished

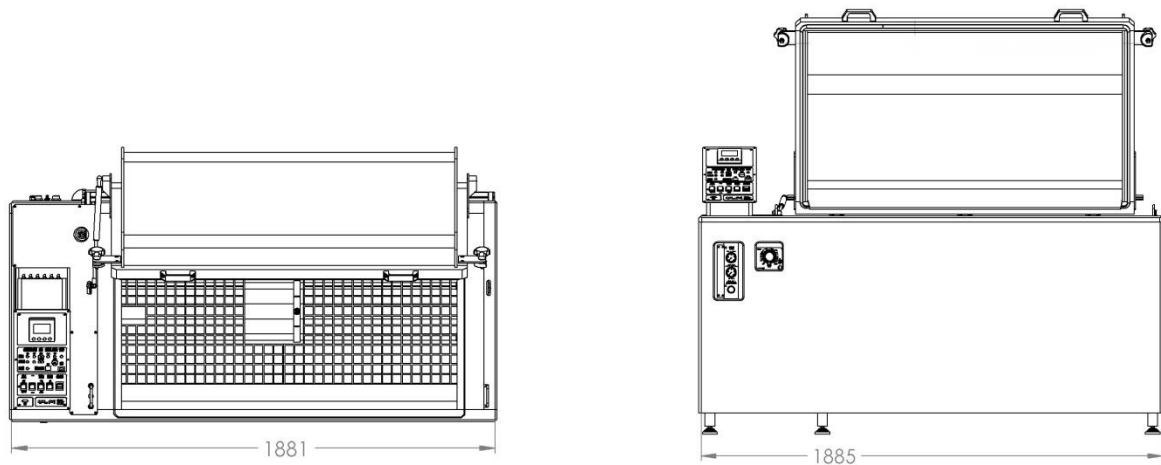

Figure 2 Dimension CCT 1000-TL D