



# Product Data Sheet

## CCT 400-FL I (+60°C)

### Relevant Test Standards:

#### Cyclic Corrosion Tests:

- DIN EN ISO 11997-1:2006 Cycle B (previously VDA 621-415)
- VW PV 1210 (climate module required)

#### Salt Spray Test:

- DIN EN ISO 9227
- DIN 50942, DIN 53167
- ASTM B 117-73, ASTM B 287-74
- ASTM B 368-68
- ISO 7253 ISO 3678
- BS 1224, BS 2011, BS3900 F4
- BS 3900 F12
- BS 5466 Part I, BS 5466 Parts 2 + 3
- NFX 41002,
- AS 21331 Section 3.1
- SIS 1841190
- JIS Z 2371
- IEC 60028-2-11 KA

#### Condensation water test:

- ISO 6270-2
- BS 3900F2, BS 3900 F15
- ASTM D2242

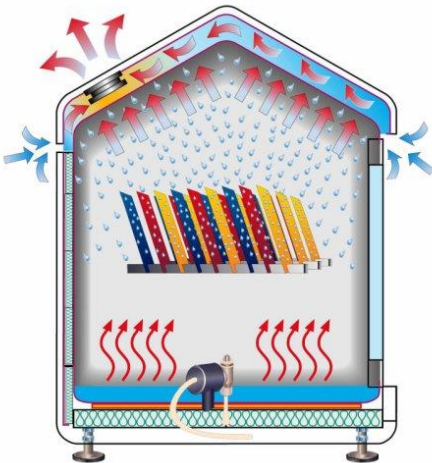

Figure 1 Patented Controlled Water Condensation (CWC) system

### Product Description

Compact front loading cabinet for corrosion testing developed for conducting advanced automatic cyclic corrosion tests pursuant to major corporate standards in the international automotive industry such as:

- DIN EN ISO 11997-1:2006 Cycle B (previously VDA 621-415)
- VW PV 1210 (external climate module required)
- GMW 14872 (external climate module required)

This test cabinet is also suitable for performing standard corrosion tests:

- Water condensation DIN EN ISO 6270-2:2005 (CH, AT, AHT), ASTM D2247
- Salt spray ISO 9227, IEC 60028-2-11 KA

### Customer Benefits

- Operating temperature from ambient up to +60°C
- Advanced steel design of the chamber allows for fast temperature and humidity transient times making this test chamber perfectly suitable for accelerated corrosion tests – these result in time and energy savings during the operational lifetime
- The patented VLM technology allows the best possible reproducibility of the climate conditions being created in the test chamber regardless the environmental conditions and geographical location
- The test chamber made of steel is more robust and less susceptible for damages compared to the competitive products made of glass reinforced plastic
- Lower cost of ownership compared to the competitive products where the test chamber is made of glass reinforced plastic (shorter test periods, better energy efficiency, easier for service and maintenance, longer life cycle, more resistive to mechanical damages)
- User friendly, menu guided and intuitive control system based on a versatile controller with colour display in which most common standard corrosion tests are already preconfigured

### Order Information

**Model:** CCT 400-FL I

Article number:

- V.731.362.120

### Sales & Support:

+49 5205 87963 0

Monday to Friday

8:00 am – 17:00 pm

VLM GmbH

Heideblümchenweg 50

33689 Bielefeld

[info@vlm-labtec.com](mailto:info@vlm-labtec.com)

[www.vlm-labtec.com](http://www.vlm-labtec.com)

Specification subject to changes  
Pictures might differ from original



# Product Data Sheet

## CCT 400-FL I (+60°C)

### Relevant Test Standards:

#### Cyclic Corrosion Tests:

- DIN EN ISO 11997-1:2006 Cycle B (previously VDA 621-415)
- VW PV 1210 (climate module required)



#### Salt Spray Test:

- DIN EN ISO 9227
- DIN 50942, DIN 53167
- ASTM B 117-73, ASTM B 287-74
- ASTM B 368-68
- ISO 7253 ISO 3678
- BS 1224, BS 2011, BS3900 F4
- BS 3900 F12
- BS 5466 Part I, BS 5466 Parts 2 + 3
- NFX 41002,
- AS 21331 Section 3.1
- SIS 1841190
- JIS Z 2371
- IEC 60028-2-11 KA



#### Condensation water test:

- ISO 6270-2
- BS 3900F2, BS 3900 F15
- ASTM D2242



Figure 2 Jumo Imago 500



Technical Specifications	
Capacity	ca. 400 L
Inner test chamber dimensions W/D/H1/H2	ca. 800 x 605 x 733/920 mm
Outer dimensions of the casing (overall) W/D/H	ca. 1310 x 670 x 1933 mm
Max. operating temperature	60°C
Required power supply	230 V, 50/60 Hz, 2200 W
Materials used	test chamber is made of stainless steel and coated with ECTFE (Halar®), additional side walls made of special Polyethylene with milled openings for supporting rods
Heating	Flat Micanite heaters under the bottom of the chamber and behind the side walls for fast and uniform heat transfer
Sensors	Corrosion resistant and highly sensitive temperature sensors above the floor and under the roof
Cooling	Not available
Regulated humidity	Not available
Other specification	
Purity demineralized water (connection type)	< 5 µS/cm (¾" outer diameter)
Tap water (connection type)	Always via Ion-exchanging cartridge (¾" outer diameter)
Compressed Air	6-8 bar (connection nipple size 5)
Waste water, drain	Pipe fittings (spiral hose ID 18 mm)
Exhaust pipe outer diameter	Pipe fitting (50 mm external diameter)
Test solution tank capacity	A 210 L tank is available which fits in the bench cabinet underneath the test chamber
Recommended accessories	Demineralized water plant, filter for compressed air, pump for mixing test solution, racks for specimen

### Process Control

- User friendly, menu guided JUMO Imago controller with colour graphic display
- Restricted access for operators to three different operating levels
- Memory storage with the capacity to hold up to 50 test programs with most common corrosion tests already preconfigured in the factory
- The controller steers the external climate module for the tests which require air conditioning (typically PV 1210)
- Full overview of all digital and analog inputs / outputs

### Operating System Salt Spray (according to ISO 9227)

- Electronically controlled diaphragm pump for accurate flow control of the test solution with automatic monitoring of the presence of the air in the pump system
- Adjustable high performance acrylic spray nozzle for an optimal generation and distribution of the salt fog
- Transparent humidifier made of heat resistant Borosilicate glass with a replaceable PE air filter
- Safety air pressure valve on the humidifier
- Over temperature protection of the humidifier
- Air purge function for rapid evacuation of the salt fog out of the chamber
- Accessories: 210 L PE storage reservoir for test solution (level indicator optional)
- Option: Aeration with warm air (WA)
- Option: Nozzle for washing the test chamber after the salt spray test is finished



# Product Data Sheet

## CCT 400-FL I (+60°C)

### The following accessories are included

- 6 rods for supporting test specimen
- 2 m exhaust hose  $\varnothing$  50 mm
- 2 m drain water hose  $\varnothing$  18 mm
- 1 female connector for compressed air hose (size no. 5)
- 1 bag sodium chloride special quality for corrosion testing, accurate weight 5000 g
- 1 set of measuring cylinders for measuring the fall out rate
- 1 spare filter for the test solution in the reservoir



### Operating system High Humidity with Controlled Water Condensation - CWC (according to ISO 6270-2 CH)

- CWC system (Figure 1) is the patented VLM technology which regulates the temperature gradient of exactly  $\Delta T=1^{\circ}\text{C}$  between the bottom and the roof of the test chamber – this is essential for an optimal condensation process in the test chamber at 100% RH regardless the environmental conditions outside the test chamber
- Flat heaters under the bottom of the chamber and behind side walls allow for uniform and rapid heating of the water in the trough
- Temperature stability in the chamber  $\pm 0,5^{\circ}\text{C}$
- Air fan with adjustable rotation speed for controllable drying of specimen in the Drying Phase

### Operating system Forced Air Drying / Aeration

- Aeration with environmental air (aeration with warm air is optional) during the forced air drying phase
- Adjustable air distribution system inside the test chamber for uniform drying of the test specimens
- Fan with controllable rotation speed
- Option: Air conditioning module for providing standard climate acc. to DIN 50014: ambient air at  $23^{\circ}\text{C} \pm 2^{\circ}\text{C}$  and  $50\% \pm 5\%$  RH

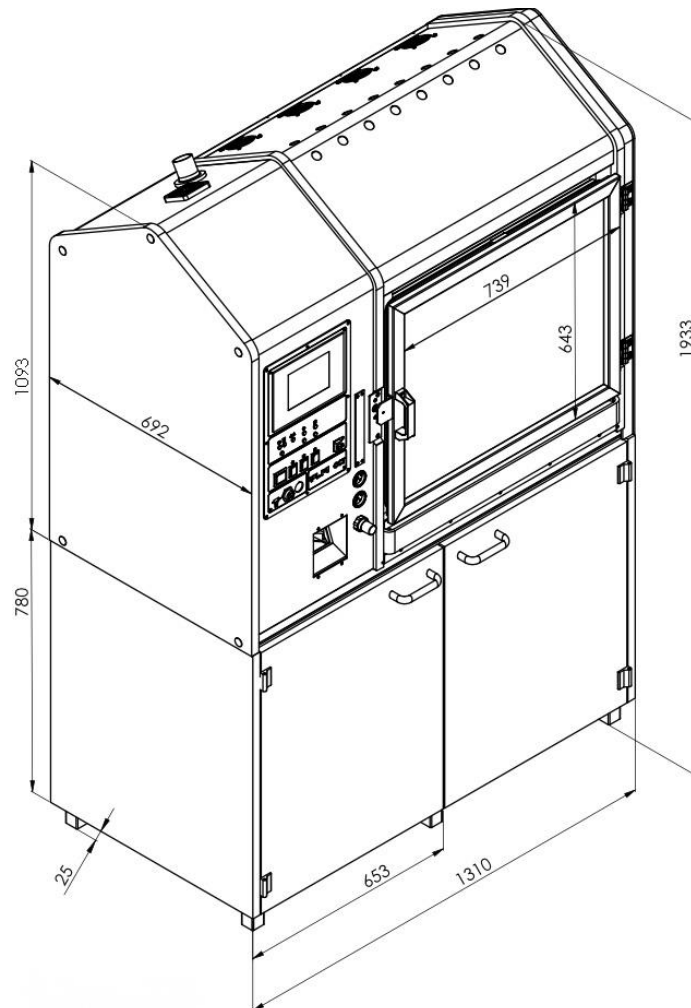

Figure 3 Mechanical dimensions CCT 400-FL-I